

ABS submersible sewage pump AFP 0831-2046

Robust, reliable submersible pumps from 1.3 to 30 kW for pumping wastewater and sewage from buildings and sites in private, commercial, industrial and municipal areas in accordance with EN 12050-1. Available as standard AFP or as higher specification AFP(K).



Applications

AFP submersible pumps have been designed for the economic and reliable pumping of clear or wastewater, gaseous liquids, and for sewage and sludge, in fixed or portable applications.

- For fixed, wet well applications the AFP is pedestal mounted. Using a self-sealing coupling system the pump seals automatically on the pedestal when lowered by guide rail into position.
- Dry well applications have the option of horizontal or vertical installation.
- With vortex hydraulics the AFP is particularly suitable for sewage, abrasive matter, and fluids containing stringy materials that tend to "rope".
- The Contrablock hydraulic system offers higher efficiency and is suitable for larger proportions of solid or fibrous matter.

Construction

The water-pressure-tight, encapsulated, fully flood-proof motor and the pump section form a compact, robust, modular construction. Maximum allowable temperature of the medium for continuous operation is 40 °C (information on applications at other temperatures available on request).

Available in explosion-proof versions in accordance with international standards EExd II BT4, FM and ATEX.

Cooling

AFP: Free-circulation cooling by the medium.

AFP(K): Closed loop cooling system with circulation of glycol and water which has no contact with the sewage being pumped. This optimises heat exchange and avoids the danger of blockage of the cooling system with sewage particles.

Dry installation is possible without cooling system, for intermittent use only and subject to strict limitations.

Bearings

The stainless steel motor shaft is supported in lubricated-for-life ball bearings.

Shaft sealing

Between the motor and hydraulic section is by means of a high quality, silicon carbide, double mechanical seal. Standard AFP has a single mechanical seal and upper lip seal. AFP(K) has the option of double mechanical seals or a seal cartridge. The seal cartridge combines both mechanical seals into a complete, easy-to-replace unit (not available with ME motor). All seals are independent of rotation direction and resistant to temperature shock.

Discharge

DN 80, 100, 150 and 200 DIN flange.

Temperature monitoring

TCS (Thermo-Control-System) with thermal sensors in the stator to switch off the pump in the case of overheating and switch on automatically after cooling down.

Seal monitoring

DI system consisting of a sensor in the motor and oil chambers which signals an inspection alert if there is leakage at the shaft seals (not in oil chamber on Ex version).

Hydraulics

AFP 0831-0835, 1031-1035, 1533: vortex, open, recessed, four-vane impeller.

AFP 0841-0844, 1041-1049, 1541, 1543 & 2045: Contrablock, open single-vane impeller.

AFP 1546 & 2046: Contrablock, open double-vane impeller.



Features

- High-efficiency hydraulic design using Contrablock or vortex impellers.
- Available as standard AFP or higher specification AFP(K).
- AFP(K) has class H insulation and double mechanical seals as standard, with options of seal cartridge and closed loop cooling system.
- Automatic seal and temperature monitoring.
- Available as explosion-proof.
- Designed for fixed or transportable installation.
- For lifting, AFP has cast eyelet, AFP(K) has stainless steel lifting hoop.

Motor

Three-phase, 400 V, 50 Hz, squirrel-cage motor as 2-pole (2900 r/min), 4-pole (1450) and 6-pole (980).

Protection type IP 68, with stator insulation Class F (155 °C) for standard AFP or Class H (180 °C) for AFP(K) version.

Direct starting up to 3 kW; from 4 kW star-delta or direct starting is possible. Motors with other operating voltages and frequencies are also available.

Identification Code: e.g. AFP 1035.3 ME 250/2

Hydraulics:

AFP Product range

10 Discharge outlet DN (cm)

35 Hydraulic number

.3 Impeller

Motor:

ME M = modular motor; E = high efficiency

250 Motor power P_2 kW x 10

2 Number of poles

Materials

Description	Material
Motor housing	Cast iron EN-GJL-250
Motor shaft	Stainless steel 1.4021 (AISI 420)
Volute	Cast iron EN-GJL-250
Impeller	Cast iron EN-GJL-250
Bottom plate	Cast iron EN-GJL-250
Fasteners	Stainless steel 1.4401 (AISI 316)

AFP(K) options: stainless steel motor shaft 1.4401 (AISI 316), stainless steel impeller 1.4460 (AISI 329), viton seals, and surface hardened cast iron impeller and bottomplate.

AFP is available in SX version as a complete stainless steel pump (see separate literature).

Technical Data

AFP	Impeller size	Solid size (mm)	Rated voltage (V)	Motor power * (kW)		Rated current (A)	Speed (r/min)	Starting	Cable type **	Weight*** (kg)	
				P ₁	P ₂						
0831	M 15/4	3, 4, 5, 6, 7	80	400 3~	2.51	1.95	4.65	1450	DOL	(a)	78/90
	M 22/4	2	80	400 3~	2.88	2.20	5.15	1450	DOL	(a)	79/90
	M 30/4	1	80	400 3~	3.95	3.00	7.00	1450	DOL	(a)	80/92
	S 22/4	2, 3	80	400 3~	2.88	2.20	5.15	1450	DOL	(e)	45/n.a.
0832	M 70/2	1, 2, 3	80	400 3~	8.37	7.00	13.60	2900	YΔ	(b)	105/121
	M 40/2	4	80	400 3~	4.86	4.00	7.93	2900	YΔ	(b)	81/93
0834	M 110/2	1, 2, 3, 4	80	400 3~	13.30	11.00	22.10	2900	YΔ	(b)	95/103
0835	M 55/2	6	65	400 3~	6.49	5.50	10.40	2900	YΔ	(b)	117/130
	M 70/2	5	65	400 3~	8.37	7.00	13.60	2900	YΔ	(b)	117/130
	M 110/2	1, 2, 3, 4	65	400 3~	13.30	11.00	22.10	2900	YΔ	(b)	129/142
0841	M 15/4	1, 2, 3, 4	80	400 3~	2.51	1.95	4.65	1450	DOL	(a)	78/90
	M 30/4	A	80	400 3~	3.95	3.00	7.00	1450	DOL	(a)	80/92
	S 22/4	1	80	400 3~	2.88	2.20	5.15	1450	DOL	(e)	56/n.a.
	S 13/4	2, 3, 4	80	400 3~	1.93	1.30	3.60	1450	DOL	(e)	41/n.a.
0842	M 40/2	1	50	400 3~	4.86	4.00	7.93	2900	YΔ	(b)	81/93
0844	M 110/2	1	45	400 3~	13.30	11.00	22.10	2900	YΔ	(b)	110/120
	M 70/2	2	45	400 3~	8.37	7.00	13.60	2900	YΔ	(b)	100/110
1031	M 30/4	1	100	400 3~	3.95	3.00	7.00	1450	DOL	(a)	80/92
	M 22/4	2	100	400 3~	2.88	2.20	5.15	1450	DOL	(a)	78/90
	M 15/4	3, 5, 6, 7	100	400 3~	2.51	1.95	4.65	1450	DOL	(a)	78/90
1032	M 90/4	A	100	400 3~	10.80	9.00	19.40	1450	YΔ	(b)	120/136
	M 60/4	1	100	400 3~	7.22	6.00	12.50	1450	YΔ	(b)	110/126
	M 40/4	2, 3, 4	100	400 3~	5.00	4.00	8.87	1450	YΔ	(b)	107/123
1033	ME 185/4	1	100	400 3~	21.30	18.50	36.50	1450	YΔ	(c)	290/320
	ME 160/4	2, 3	100	400 3~	18.20	16.00	32.00	1450	YΔ	(c)	285/315
	ME 110/4	4	100	400 3~	12.70	11.00	22.10	1450	YΔ	(b)	280/310
1034	ME 250/2	1, 2, 3, 4, 5, 6	75	400 3~	28.40	25.00	44.60	2900	YΔ	(d)	240/270
	ME 200/2	1, 2, 3, 4, 5, 6	75	400 3~	22.30	20.00	35.00	2900	YΔ	(c)	230/260
	ME 185/2	7	75	400 3~	20.40	18.50	32.30	2900	YΔ	(c)	225/255
	ME 150/2	8	75	400 3~	16.70	15.00	27.10	2900	YΔ	(c)	220/250
1035	ME 150/2	6, 7	64	400 3~	16.70	15.00	27.10	2900	YΔ	(c)	222/250
	ME 200/2	5	64	400 3~	22.30	20.00	35.00	2900	YΔ	(c)	227/255
	ME 250/2	1, 2, 3, 4	64	400 3~	28.40	25.00	44.60	2900	YΔ	(d)	232/260
1041	M 30/4	1,2	90	400 3~	3.95	3.00	7.00	1450	DOL	(a)	80/92
	M 22/4	3	90	400 3~	2.88	2.20	5.15	1450	DOL	(a)	78/90
	M 15/4	4	90	400 3~	2.51	1.95	4.65	1450	DOL	(a)	78/90
1042	M 90/4	A	100	400 3~	10.80	9.00	19.40	1450	YΔ	(b)	117/133
	M 60/4	1, 2	100	400 3~	7.22	6.00	12.50	1450	YΔ	(b)	110/126
	M 40/4	3	100	400 3~	5.00	4.00	8.87	1450	YΔ	(b)	107/123
1043	M 70/2	1	55	400 3~	8.37	7.00	13.60	2900	YΔ	(b)	105/121
1045	ME 220/4	A	100	400 3~	24.70	22.00	43.10	1450	YΔ	(d)	300/320
	ME 185/4	1	100	400 3~	21.30	18.50	36.50	1450	YΔ	(c)	290/320
	ME 160/4	2, 2B	100	400 3~	18.20	16.00	32.00	1450	YΔ	(c)	285/315
	ME 140/4	2B	100	400 3~	16.40	14.00	28.80	1450	YΔ	(b)	285/315
	ME 110/4	3	100	400 3~	12.70	11.00	22.10	1450	YΔ	(b)	280/310
1048	ME 250/2	1	50	400 3~	28.40	25.00	44.60	2900	YΔ	(d)	250/275
	ME 185/2	2	50	400 3~	20.40	18.50	32.30	2900	YΔ	(c)	245/270
	ME 150/2	3	50	400 3~	16.70	15.00	27.10	2900	YΔ	(c)	240/265
1049	M 90/4	A, 2	80	400 3~	10.80	9.00	19.40	1450	YΔ	(b)	129/145
	M 60/4	3	80	400 3~	7.22	6.00	12.50	1450	YΔ	(b)	119/135
	M 40/4	4	80	400 3~	5.00	4.00	8.87	1450	YΔ	(b)	111/127
1533	ME 185/4	1	100	400 3~	21.30	18.50	36.50	1450	YΔ	(c)	295/325
	ME 160/4	2	100	400 3~	18.20	16.00	32.00	1450	YΔ	(c)	290/320
	ME 140/4	3	100	400 3~	16.40	14.00	28.80	1450	YΔ	(b)	285/315
	ME 110/4	4	100	400 3~	12.70	11.00	22.10	1450	YΔ	(b)	285/315
1541	M 90/4	A	100	400 3~	10.80	9.00	19.40	1450	YΔ	(b)	122/133
	M 60/4	1, 2	100	400 3~	7.22	6.00	12.50	1450	YΔ	(b)	110/126
	M 40/4	3, 4, 5	100	400 3~	5.00	4.00	8.87	1450	YΔ	(b)	107/123
1543	ME 220/4	A	100	400 3~	24.70	22.00	43.10	1450	YΔ	(d)	300/330
	ME 185/4	1	100	400 3~	21.30	18.50	36.50	1450	YΔ	(c)	295/325
	ME 160/4	2	100	400 3~	18.20	16.00	32.00	1450	YΔ	(c)	290/320
	ME 140/4	2B	100	400 3~	16.40	14.00	28.80	1450	YΔ	(b)	290/320
	ME 110/4	3	100	400 3~	12.70	11.00	22.10	1450	YΔ	(b)	285/315

Electrical and cable data is for 400 V version only; data for alternative voltages available on request.

 * P₁ = power at mains; P₂ = power at motor shaft

** Neoprene cable: (a) 7G1.5 (b) 10G1.5 (c) 10G2.5 (d) 4G4 + 2x0.75 (ME 250 motor requires two cables) (e) 4G1.5 [4G1.5 + 3x0.75 for version with klixon]

*** without/with cooling jacket

Technical Data

AFP	Impeller size	Solid size (mm)	Rated voltage (V)	Motor power * (kW)		Rated current (A)	Speed (r/min)	Starting	Cable type**	Weight*** (kg)	
				P ₁	P ₂						
1546	M 90/4	A	75	400 3~	10.80	9.00	19.40	1450	YΔ	(b)	122/133
	M 60/4	2	75	400 3~	7.22	6.00	12.50	1450	YΔ	(b)	110/126
	M 40/4	4	75	400 3~	5.00	4.00	8.87	1450	YΔ	(b)	107/123
2045	ME 220/4	1	125x100	400 3~	24.70	22.00	43.10	1450	YΔ	(d)	330/360
	ME 185/4	1	125x100	400 3~	21.30	18.50	36.50	1450	YΔ	(c)	330/360
	ME 160/4	2	125x100	400 3~	18.20	16.00	32.00	1450	YΔ	(c)	325/355
	ME 140/4	3	125x100	400 3~	16.40	14.00	28.80	1450	YΔ	(b)	290/320
	ME 110/4	4	125x100	400 3~	12.70	11.00	22.10	1450	YΔ	(b)	320/350
2046	ME 140/6	1	125x100	400 3~	16.10	14.00	28.80	980	YΔ	(c)	330/360
	ME 110/6	2	125x100	400 3~	12.60	11.00	24.00	980	YΔ	(b)	325/355
	ME 90/6	4, 5	125x100	400 3~	10.40	9.00	21.40	980	YΔ	(b)	325/355

Electrical and cable data is for 400 V version only; data for alternative voltages available on request.

* P₁ = power at mains; P₂ = power at motor shaft

** Neoprene cable: (a) 7G1.5 (b) 10G1.5 (c) 10G2.5 (d) 4G4 + 2x0.75 (ME 250 motor requires two cables) (e) 4G1.5 (4G1.5 + 3x0.75 for version with klixon)

*** without/with cooling jacket

Contrablock

The Contrablock impeller design ensures clog-free pumping combined with high-efficiency hydraulic performance. It can handle solid sizes up to 125 x 100 mm, including fibres and fabric which can block conventional pumping systems.

1. Shearing ring on the upper shroud of the impeller to protect the mechanical seal.
2. Open, single- or double-vane impeller with sloped deflector edge at the impeller blade.
3. Large suction inlet.
4. Bottom plate with continuous spiral groove which assists in transporting stringy material from the inlet to the discharge.
5. Gap between bottom plate and impeller is easily adjusted to restore efficiency in the event of wear.

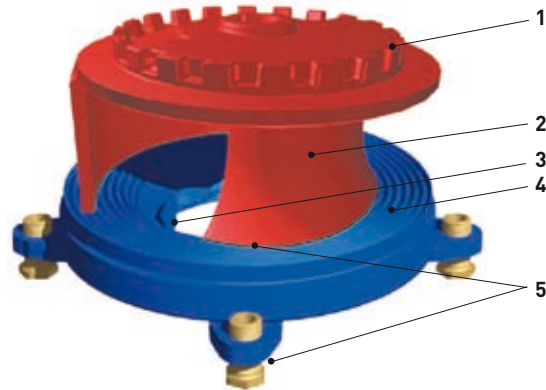

AFP(K) cross-section

1. Stainless steel lifting hoop.
2. Motor shaft ball bearings with permanent maintenance-free lubrication.
3. Motor with thermal sensors in each phase.
4. Stainless steel motor shaft.
5. Closed-loop cooling system with internal recirculation impeller.
6. Seal-minder sensor for detection of moisture in oil and motor chambers.
7. Seal cartridge unit with double mechanical seals.
8. Contrablock (featured) or vortex impeller.

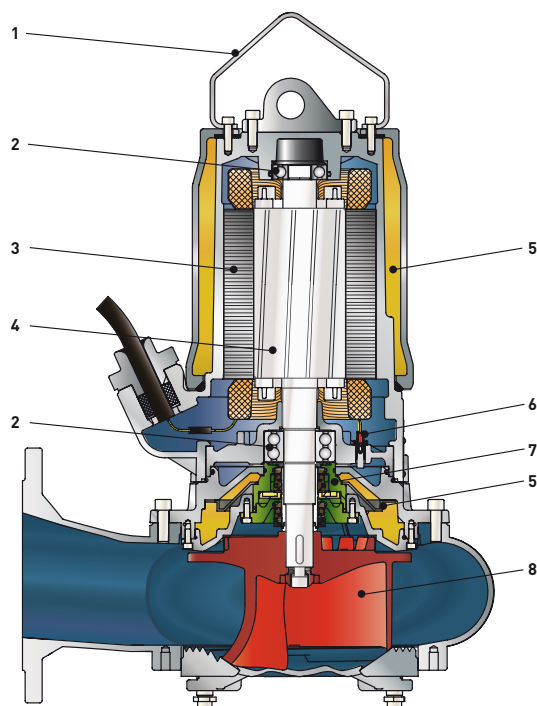

Performance Curves

AFP 0831

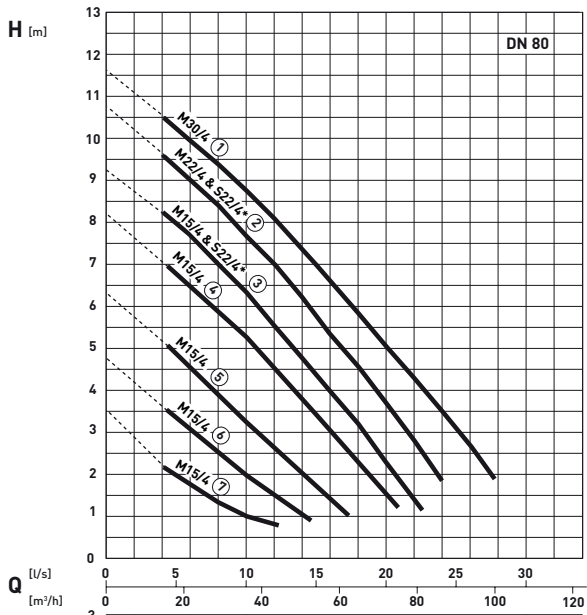

* Use only M-motor when fitted with cooling jacket

AFP 0832

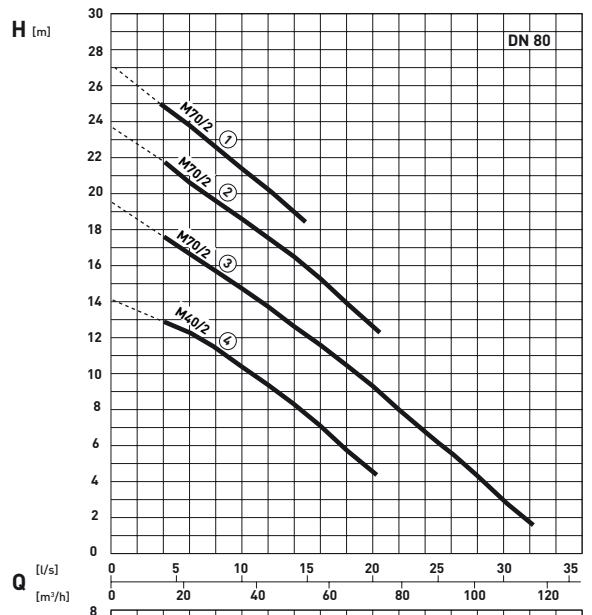

AFP 0834

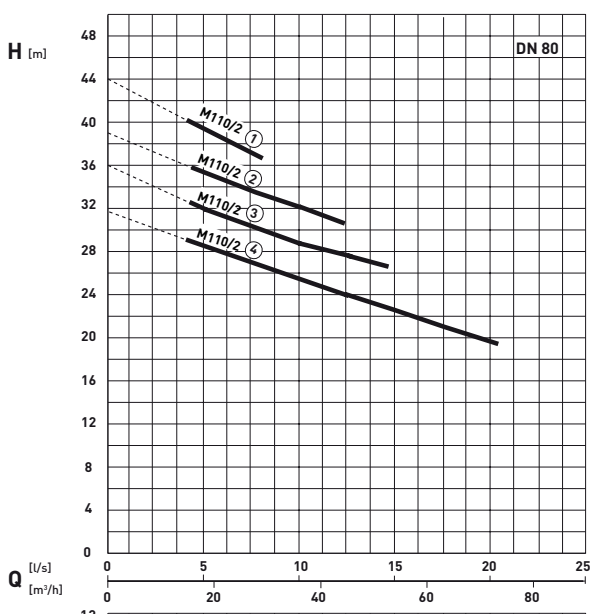

AFP 0835

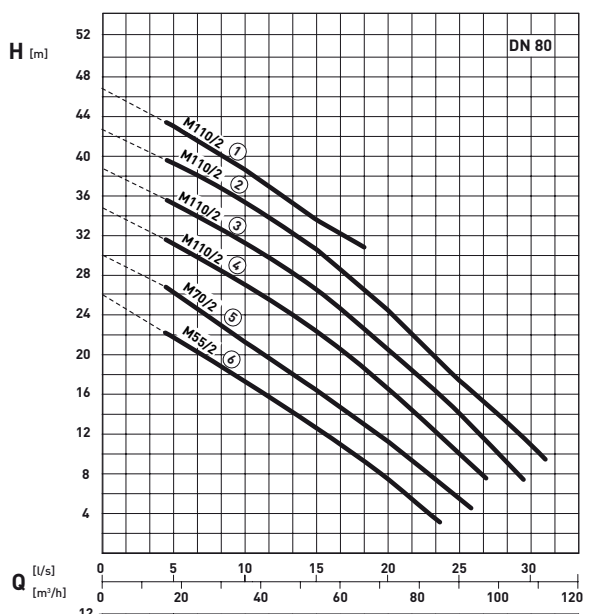

H = Total Head Q = Discharge Volume P₂ = Power at motor shaft

Curves to ISO 9906

N.B. Please use the ABSEL program to validate pump selection.

AFP 0841

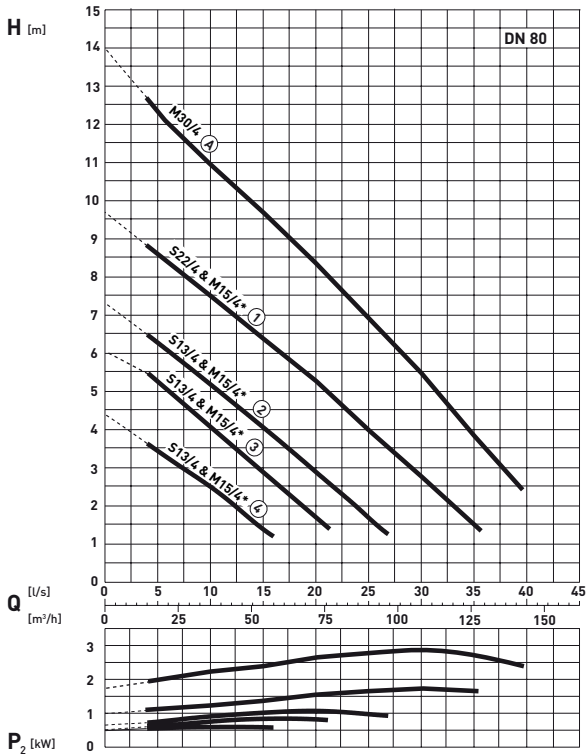

* Use only M-motor when fitted with cooling jacket

AFP 0842

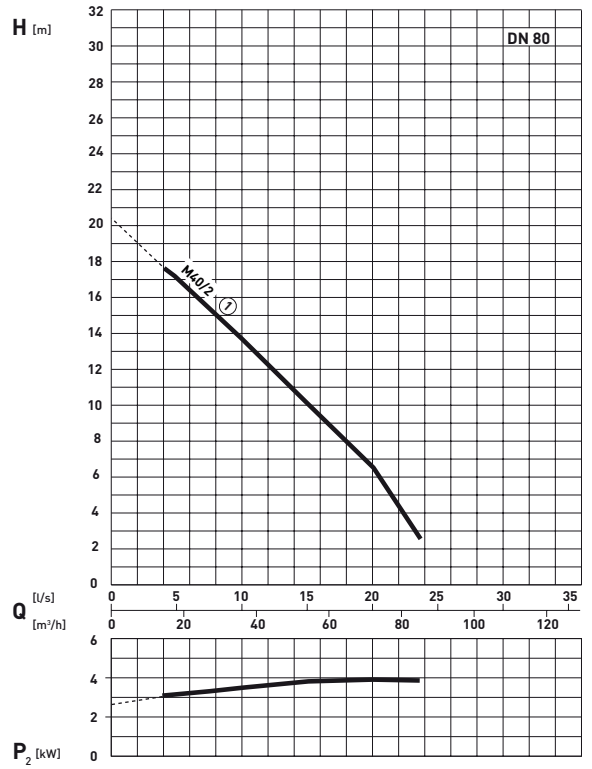

AFP 0844

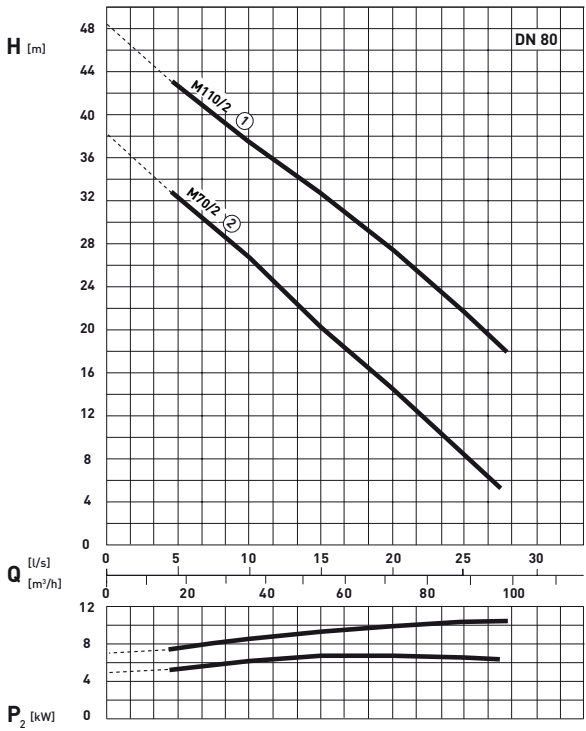

AFP 1031

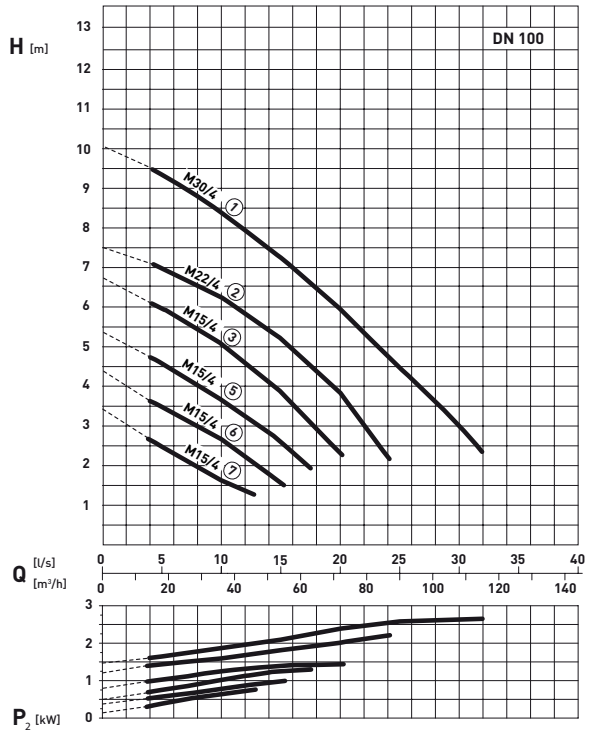

Performance Curves

AFP 1032

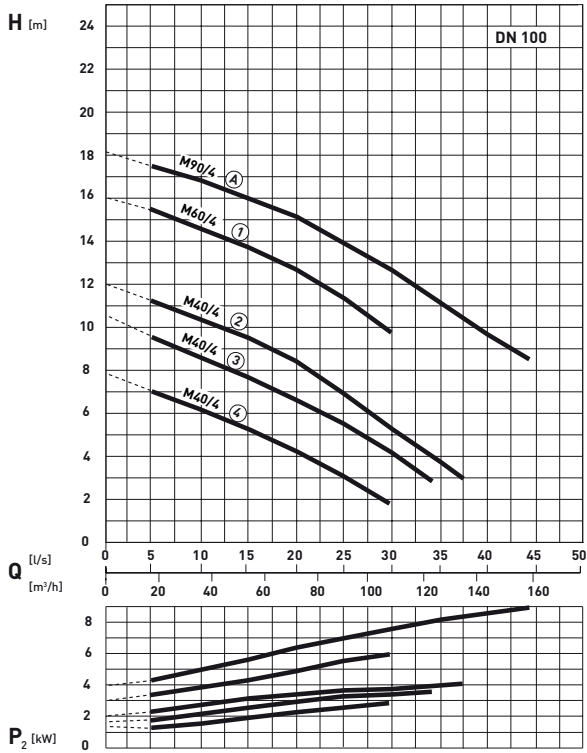

AFP 1033

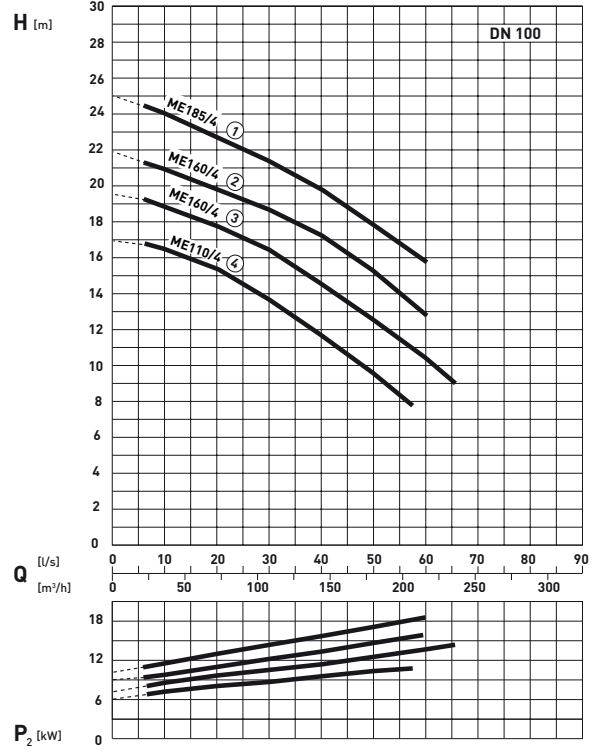

AFP 1034

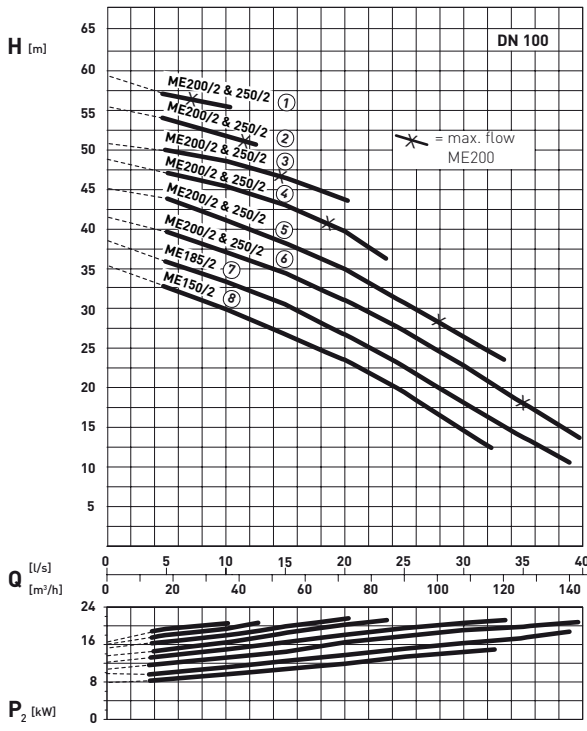

AFP 1035

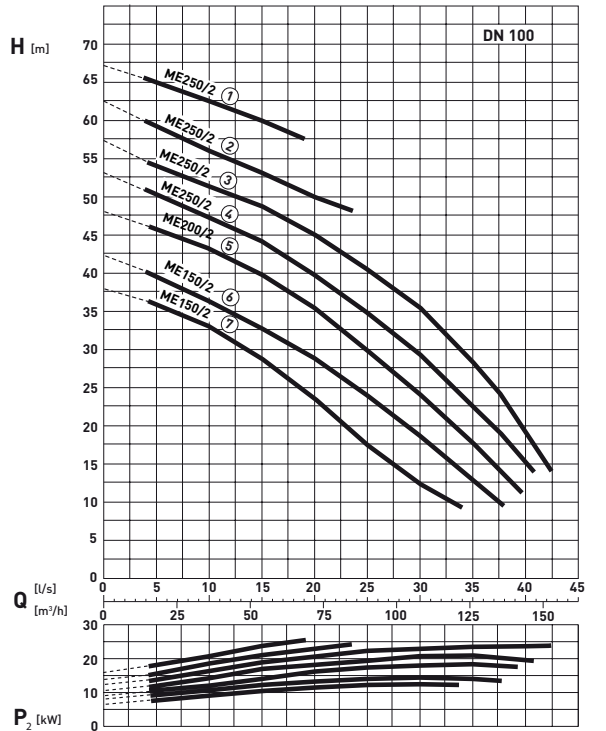

H = Total Head Q = Discharge Volume P₂ = Power at motor shaft Curves to ISO 9906 N.B. Please use the ABSEL program to validate pump selection.

AFP 1041

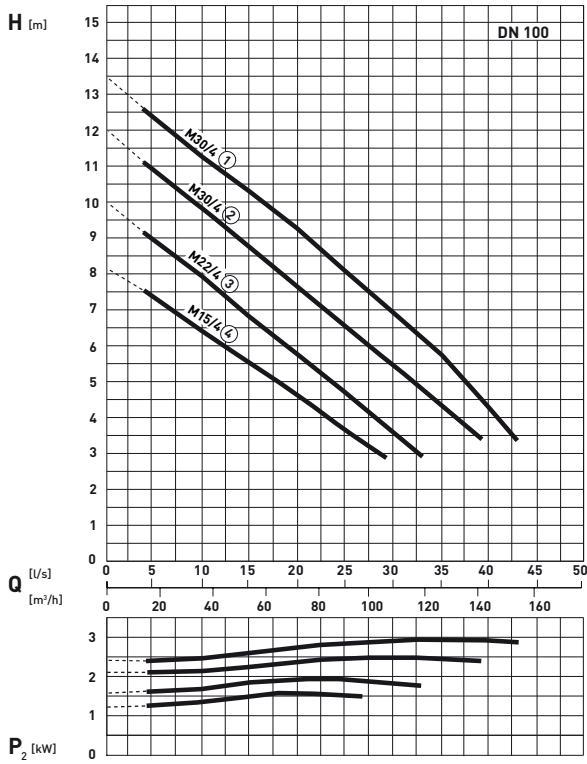

AFP 1042

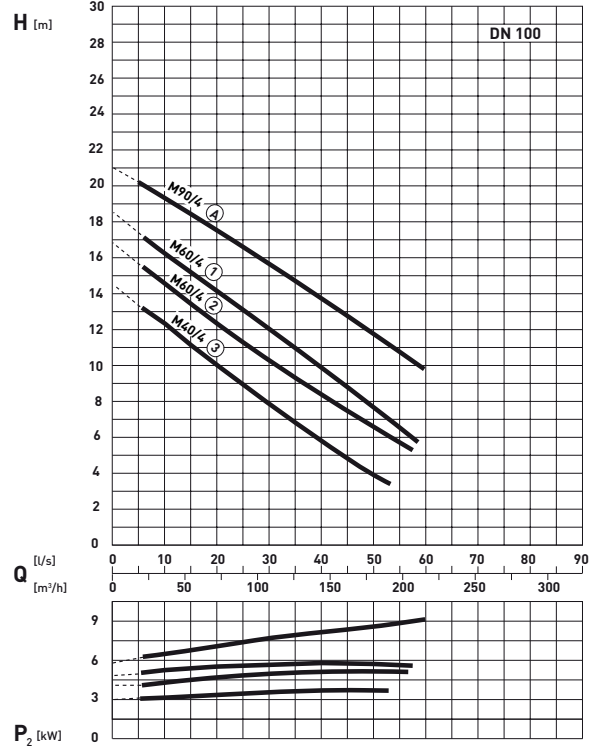

AFP 1043

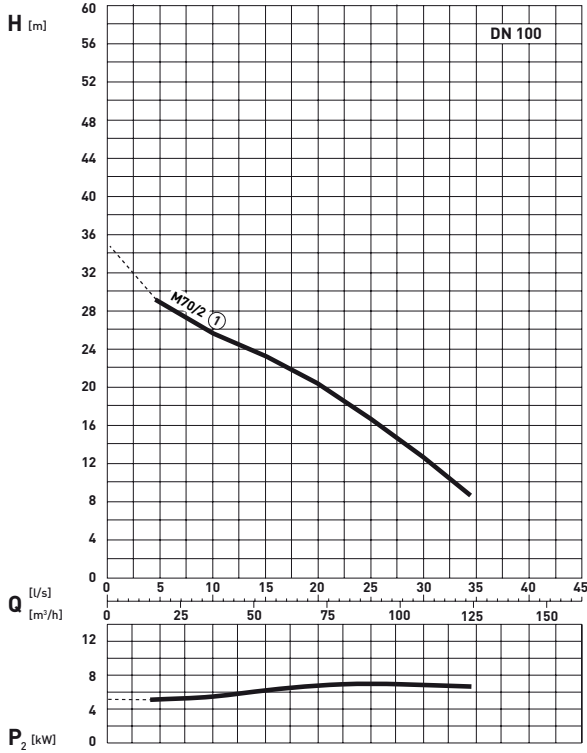

AFP 1045

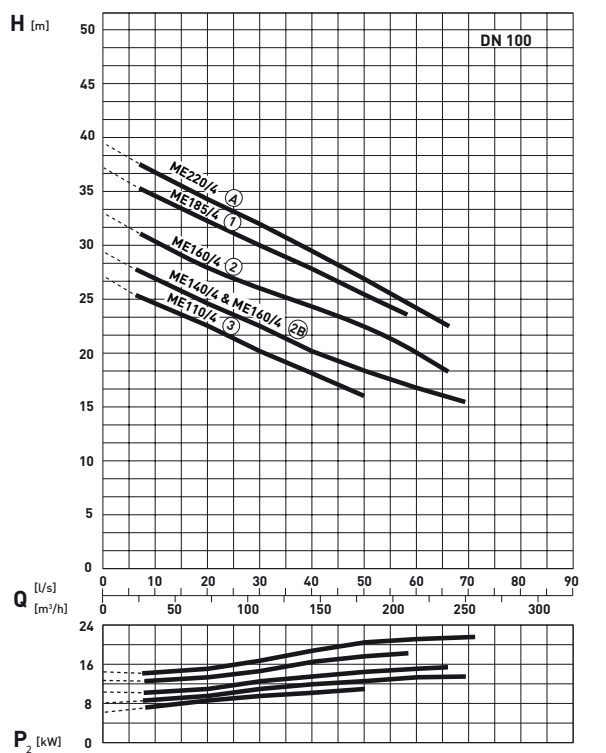

Performance Curves

AFP 1048

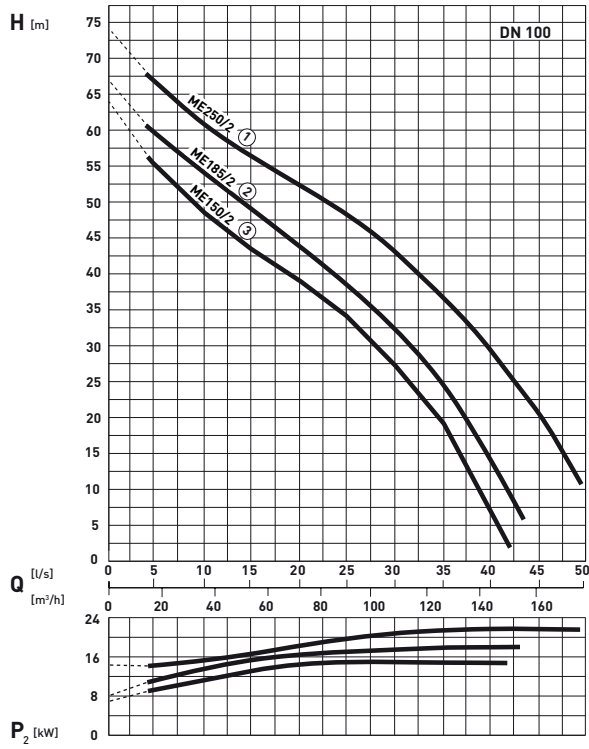

AFP 1049

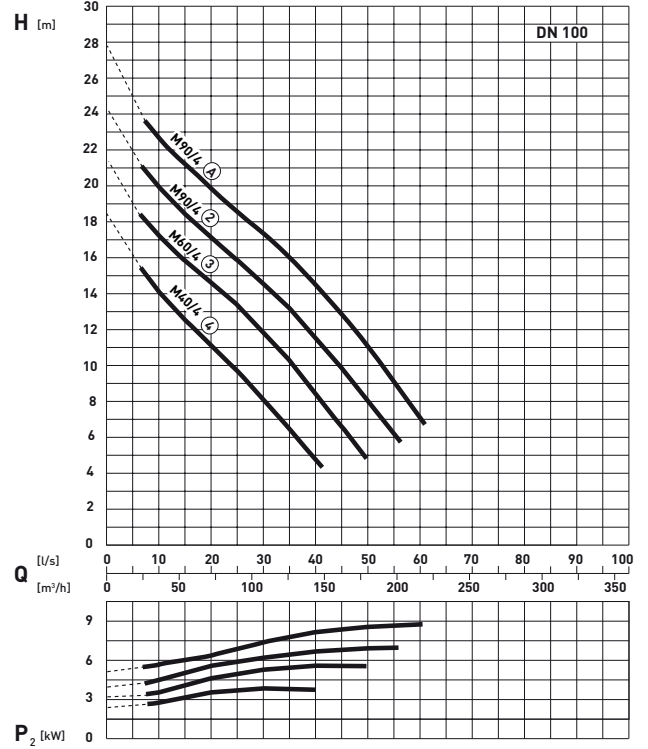

AFP 1533

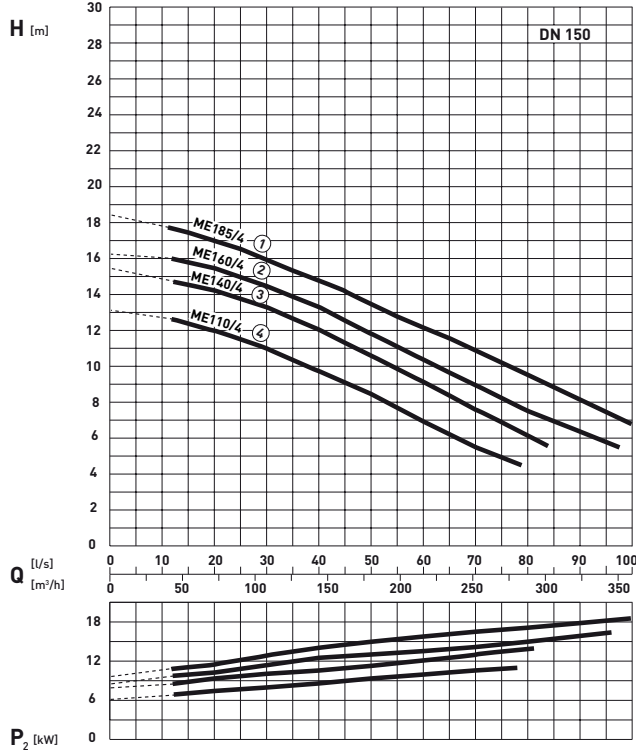

AFP 1541

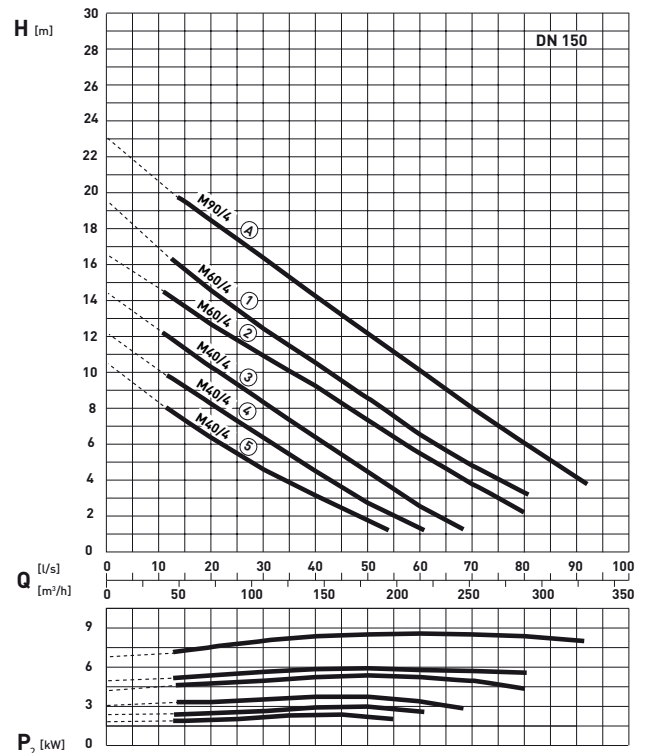

H = Total Head Q = Discharge Volume P₂ = Power at motor shaft Curves to ISO 9906 N.B. Please use the ABSEL program to validate pump selection.

AFP 1543

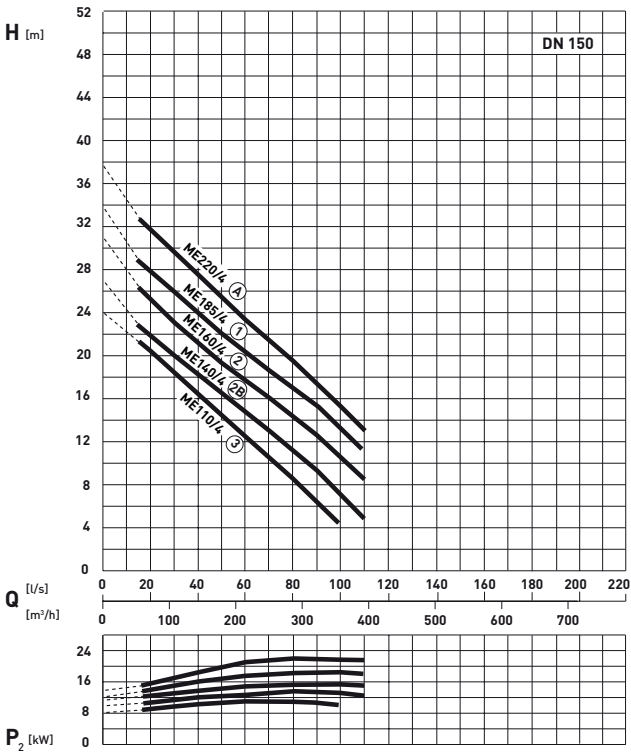

AFP 1546

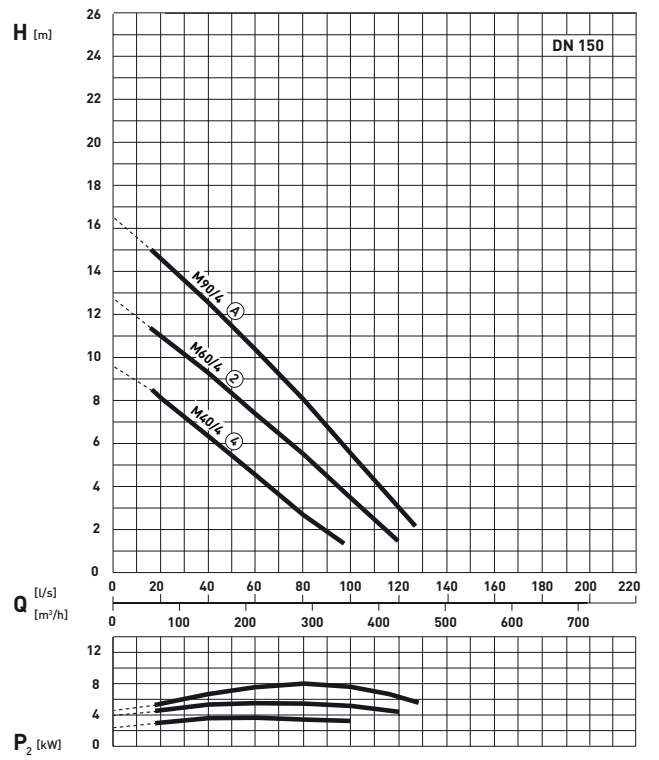

AFP 2045

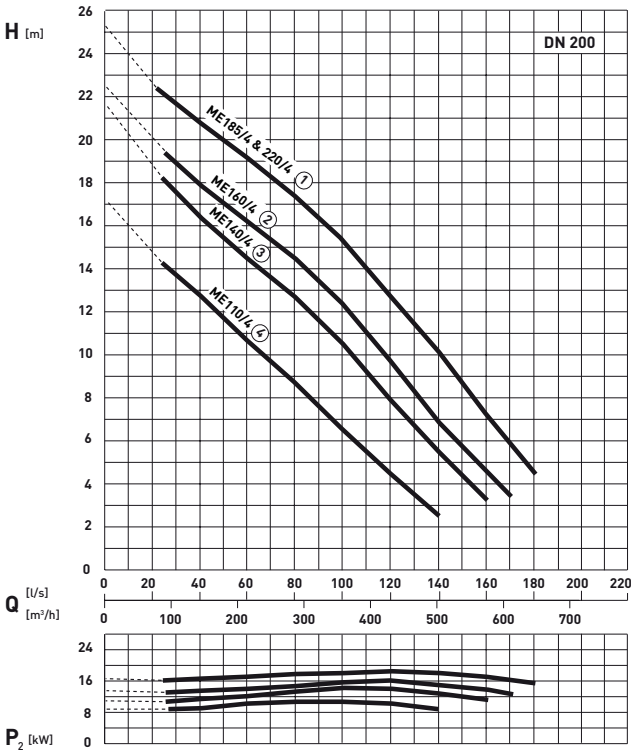

AFP 2046

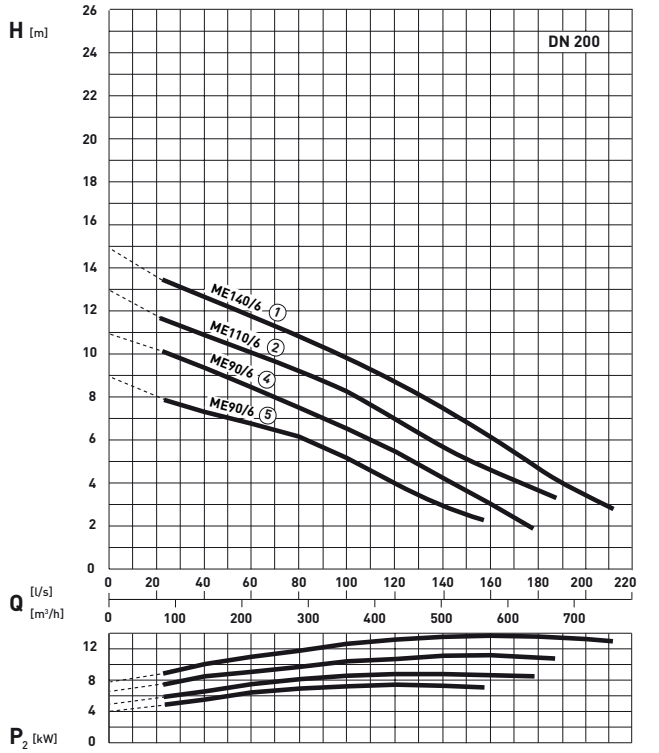

Dimensions (mm)

AFP	DN1	DN2	A	B	C	D	E	F	G	G1	G2	G3	H	J	K	L	M	N
0831	80	80	167	88	340	200	250	651	275	700	256	350	100	161	162	625	210	130
0832 M70/2	80	80	167	88	340	200	250	696	275	700	256	350	100	161	162	625	210	130
0832 M40/2	80	80	167	88	340	200	250	651	275	700	256	350	100	161	162	625	210	130
0834	80	80	167	88	340	200	250	746	275	700	256	350	100	161	162	625	210	130
0835	80	80	167	88	340	200	265	665	280	823	323	370	136	172	172	742	242	180
0835 M110/2	80	80	167	88	340	200	265	715	280	823	323	370	136	172	172	742	242	180
0841	80	100	167	88	340	200	240	653	270	818	325	327	115	167	141	748	252	180
0842	80	100	167	88	340	200	240	653	270	818	325	327	115	167	141	748	252	180
0844 M70/2	80	100	167	88	342	200	230	689	258	787	330	300	102	154	140	729	272	218
0844 M110/2	80	100	167	88	342	200	230	739	258	787	330	300	102	154	140	729	272	218
1031	100	100	180	92	370	225	250	671	310	720	305	370	115	161	162	633	220	130
1032	100	100	180	92	370	225	250	731	323	747	320	362	113	180	180	649	222	130
1032 M90/4	100	100	180	92	370	225	250	781	323	747	320	362	113	180	180	649	222	130
1033	100	150	180	92	371	225	315	1158	330	787	391	475	91	252	212	682	286	204
1034	100	100	243	98	425	249	250	1104	325	725	398	370	137	180	180	649	322	210
1035 DN80	80	100	180	168	370	200	300	1071	290	540	358	370	135	173	173	450	268	218
1035 DN100	100	100	243	100	425	249	300	1071	339	540	358	370	184	173	173	450	268	218
1041	100	100	180	92	371	225	265	658	275	817	313	344	90	191	160	769	269	180
1042	100	100	180	92	371	225	265	731	285	845	345	367	74	212	168	786	286	180
1042 M90/4	100	100	180	92	371	225	265	781	285	845	345	367	74	212	168	786	286	180
1043	100	100	180	92	371	225	240	721	285	825	330	310	86	168	168	764	269	180
1045	100	150	180	92	371	225	315	1145	330	787	391	475	86	252	212	682	286	204
1048	100	100	243	98	425	249	270	1077	311	516	334	320	150	172	172	454	272	218
1049	100	100	180	92	371	225	280	717	308	831	369	370	112	214	171	748	286	218
1049 M90/4	100	100	180	92	371	225	280	767	308	831	369	370	112	214	171	748	286	218
1533	150	150	210	98	463	280	335	1166	383	795	423	470	136	278	220	692	320	228
1541	150	150	210	98	463	280	310	731	340	845	345	375	129	240	190	786	286	180
1541 M90/4	150	150	210	98	463	280	310	781	340	845	345	375	129	240	190	786	286	180
1543	150	150	210	98	463	280	335	1153	383	795	423	470	131	278	220	692	320	228
1546	150	150	210	98	463	280	310	731	340	845	383	370	130	240	190	786	324	218
1546 M90/4	150	150	210	98	463	280	310	781	340	845	383	370	130	240	190	786	324	218
2045	200	200	245	135	550	320	400	1192	442	834	488	470	151	328	241	712	366	254
2046	200	200	245	135	550	320	400	1192	442	834	488	470	151	328	241	712	366	254

DN1 = Discharge, DN2 = Suction.

Dimensions F, O, P, S measured from cast lifting eyelet available on request (for AFP-S and AFP without lifting hoop).

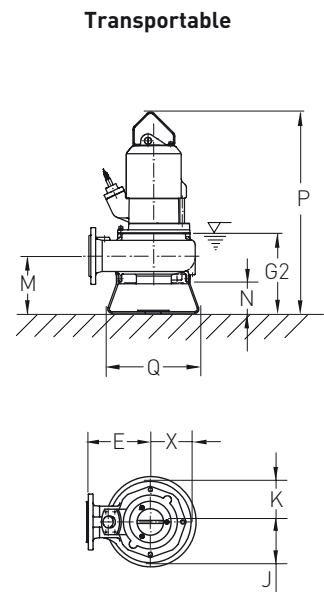
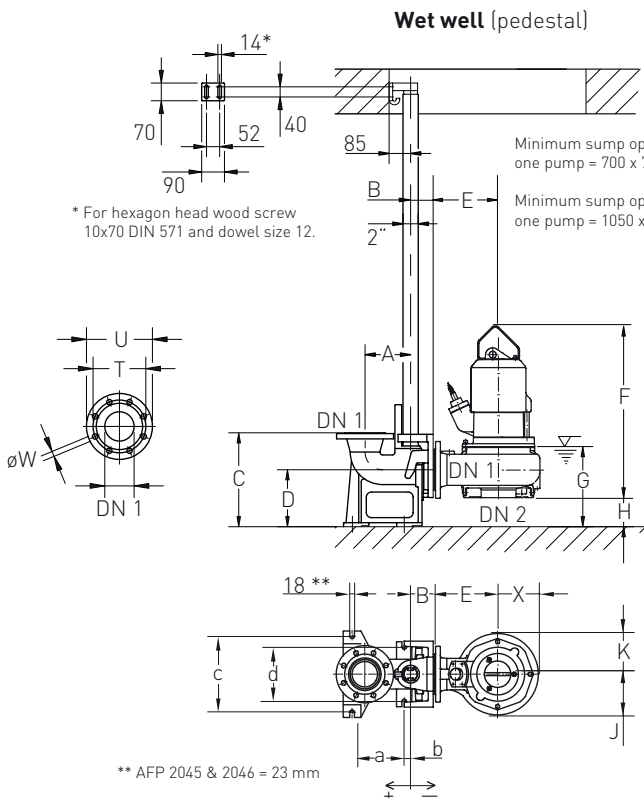

AFP	O	P	Q	R	S	T	U	W	X	Y	Z	a	b	c	d	e	f	g	h	j
0831	1176	755	348	525	651	160	200	18	161	100	235	207	+25	275	195	450	300	113	555	75
0832 M70/2	1221	866	348	525	696	160	200	18	161	100	235	207	+25	275	195	450	300	113	621	75
0832 M40/2	1176	755	348	525	651	160	200	18	161	100	235	207	+25	275	195	450	300	113	555	75
0834	1271	910	348	525	746	160	200	18	161	100	235	207	+25	275	195	450	300	113	665	75
0835	1343	845	500	678	665	160	200	18	172	64	235	207	+25	275	195	450	300	110	610	75
0835 M110/2	1393	895	500	678	715	160	200	18	172	64	235	207	+25	275	195	450	300	110	660	75
0841	1287	793	425	580	707*	160	200	18	155	167*	200	207	+25	275	195	365	250	115	552	72
0842	1287	793	425	580	707*	160	200	18	155	167*	200	207	+25	275	195	365	250	115	552	72
0844 M70/2	1318	862	550	652	666*	160	200	18	143	76*	200	207	+25	275	195	365	250	96	589	72
0844 M110/2	1368	912	550	652	716*	160	200	18	143	76*	200	207	+25	275	195	365	250	96	639	72
1031	1196	765	348	525	671	180	225	18	161	110	235	230	+25	300	215	450	300	123	576	75
1032	1268	841	348	537	731	180	225	18	180	112	235	230	+25	300	215	450	300	137	655	75
1032 M90/4	1318	891	348	537	781	180	225	18	180	112	235	230	+25	300	215	450	300	137	705	75
1033	1706	1310	682	575	1131	180	225	18	231	122	310	230	+25	300	215	541	400	122	929	93
1034	1641	1314	520	537	1104	180	225	18	180	112	235	193	-57	260	260	450	300	137	912	75
1035 DN80	1456	1274	605	385	1071	160	200	18	173	65	235	200	-48	160	160	450	300	98	887	72
1035 DN100	1456	1274	605	385	1071	180	225	18	173	65	235	193	-57	260	260	450	300	98	887	72
1041	1295	793	500	576	719*	180	225	18	176	194*	235	230	+25	300	215	450	300	137	556	75
1042	1366	866	440	540	826*	180	225	18	189	246*	235	230	+25	300	215	450	300	154	632	75
1042 M90/4	1416	916	440	540	876*	180	225	18	189	246*	235	230	+25	300	215	450	300	154	682	75
1043	1346	851	425	581	765*	180	225	18	168	183*	200	230	+25	300	215	365	250	131	616	72
1045	1688	1292	682	575	1113	180	225	18	231	107	310	230	+25	300	215	541	400	122	911	93
1048	1432	1250	550	378	1054	180	225	18	172	76	200	193	-57	260	260	365	250	96	857	72
1049	1352	890	605	663	689	180	225	18	193	35	235	230	+25	300	215	450	300	116	625	75
1049 M90/4	1402	940	605	663	739	180	225	18	193	35	235	230	+25	300	215	450	300	116	675	75
1533	1714	1342	682	575	1139	240	285	23	246	117	310	272	-18	270	270	541	400	132	934	93
1541	1366	866	500	540	826*	240	285	23	215	246*	235	272	-18	270	270	450	300	154	633	75
1541 M90/4	1416	916	500	540	876*	240	285	23	215	246*	235	272	-18	270	270	450	300	154	683	75
1543	1696	1324	682	587	1109	240	285	23	246	106	310	272	-18	270	270	541	400	132	919	93
1546	1366	904	605	616	750*	240	285	23	215	171*	235	272	-18	270	270	450	300	154	639	75
1546 M90/4	1416	954	605	616	800*	240	285	23	215	171*	235	272	-18	270	270	450	300	154	689	75
2045	1734	1389	682	567	1167	295	340	23	289	144	310	300	-130	420	340	541	400	152	958	93
2046	1734	1389	682	567	1167	295	340	23	289	144	310	300	-130	420	340	541	400	152	958	93

* Includes flange DIN 2633, PN 16; AFP 1546 includes 5" to DN150 adaptor flange.

Dry well vertical

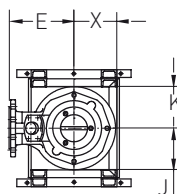
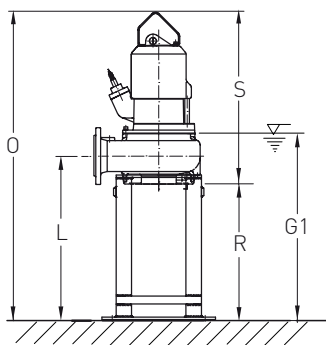

Dry well horizontal

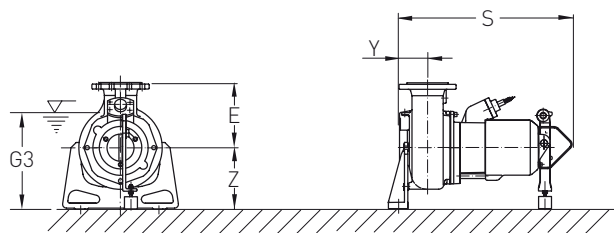

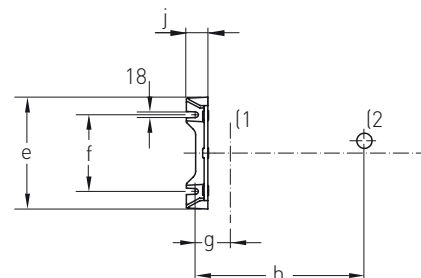

= Lowest switch-off point for automatic control

Volute Support (horizontal installation)

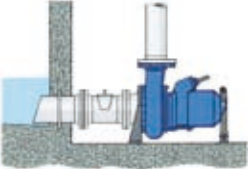
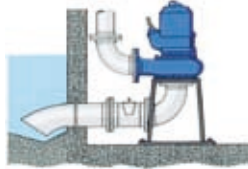

{1 = Centre of discharge line, {2 = Centre of head support

Accessories

	Description	Size	Part no.	AFP		
<p>Fixed installation - wet well with ABS Automatic Coupling System</p> 	<p>Pedestal* (cast iron EN-GJL-250) 90° cast bend - plug/clamp connection (with fixing bolts)</p>	DN 80 (pipe Ø90 mm)	62320650	0831-0844		
		DN 100 (pipe Ø109 mm)	62320653	1031-1033, 1041-1045, 1049		
		DN 100 high head (Ø109 mm)	62325020	1034, 1035, 1048		
		DN 100 (pipe Ø115 mm)	62320654	1031-1033, 1041-1045, 1049		
		DN 150 (pipe Ø160 mm)	62320656	1533-1546		
		DN 150 (pipe Ø169 mm)	62320657	1533-1546		
	<p>90° cast bend - flange connection (fixing bolts not included)</p>	DN 80	62320649	0831-0844		
		DN 100	62320652	1031-1033, 1041-1045, 1049		
		DN 100 (high-head)	62325019	1034, 1035, 1048		
		DN 150	62320655	1533-1546		
		DN 200	62320658	2045 & 2046		
		<p>flange connection without bend (with fixing bolts)</p>	DN 80	62320517	0831-0844	
	DN 100		62320516	1031-1045, 1049		
	DN 150		62320537	1533-1546		
	<p>Chain Kit (galvanized steel) including shackle</p>	3 m	61265065	0831-2046		
4 m		61265093				
6 m		61265069				
7 m		61265096				
<p>Chain Kit (stainless steel) including shackle</p>		3 m	61265081		0831-2046	
		4 m	61265099			
		6 m	61265085			
	7 m	61265102				
<p>Fixed installation - dry well, (horizontal)</p> 	<p>Pump Support Kit (EN-GJL-250) head and volute supports with fixing bolts and vibration damper</p>		61820025	0841/M, 0842, 0844, 1043		
			61820040	0831/M, 0832, 0834, 1031, 1041		
			61820041	1032, 1042, 1049, 1541, 1546		
			61825001	0831/S, 0841/S		
			61825007	1033, 1045, 1533 1543, 2045, 2046		
			61825008	0835, 1034, 1035		
			61825009	1048		
		<p>(vertical)</p> 	<p>Ground Support Stand</p>		61355000	0831/M, 0832, 0834, 1031, 1032, 1034
					61355001	0835, 1041, 1042, 1049, 1541, 1546
					61355002	0831/S, 0841/S, 0841/M, 0842, 1043
	61355003			1033, 1045, 1533, 1543, 2045, 2046		
	61355008			1035		
	61355011			0844, 1048		
<p>Transportable</p> 	<p>Ground Support Stand</p>		61350525	0831/M, 0832, 0834, 1031, 1032		
			61350526	0831/S, 0841/S, 0841/M, 0842, 1043		
			61350527	0835, 1041, 1042, 1541		
			61355004	1033, 1045		
			61355005	1035, 1049		
			61355006	1533, 1543		
			61355007	2045, 2046		
			61355009	1034		
			61355010	0844, 1048		
		<p>General</p>	<p>Non-return Valve (EN-GJL-250) ball valve with inspection hatch</p>		61400523	0831-0844
	61400524			1031-1049		
	61400541			1533-1546		
<p>ball valve with inspection hatch and venting screw</p>			61400534	0831-0844		
			61400535	1031-1049		
			61400542	1533-1546		
<p>Gate Valve (EN-GJL-250)</p>			61420500	0831-0844		
			61420501	1031-1049		
			61420503	1533-1546		
		61420504	2045 & 2046			

* 2-inch guide rail not included